

GreenWing - a first step towards electrification



Vernamack AB



The project

- Wing optimized for
 - 2-seater
 - 2 hour range
 - Electric motor
- Blackwing aircraft - BW 600
- Budget – 5.2 MSEK (480 k€)

Why GreenWing?

- Light Sport Aircraft and Trainers are well suited for electric aircraft
- Potential market - 25 000 a/c
- We have the know how



Vernamack AB



The partners

- Blackwing - Aircraft
- Green Flyway - 50 test flights
- Mid Sweden University collect and analyze data
- Mid Sweden University will specify an electric drive line
- Vernamack AB – project manager



Vernamack AB



Existing aircraft

NLF (600kg Lätt Nationellt Flygplan + 400km/h TAS)
EASA CS-LSA



Lighter, faster, Stronger

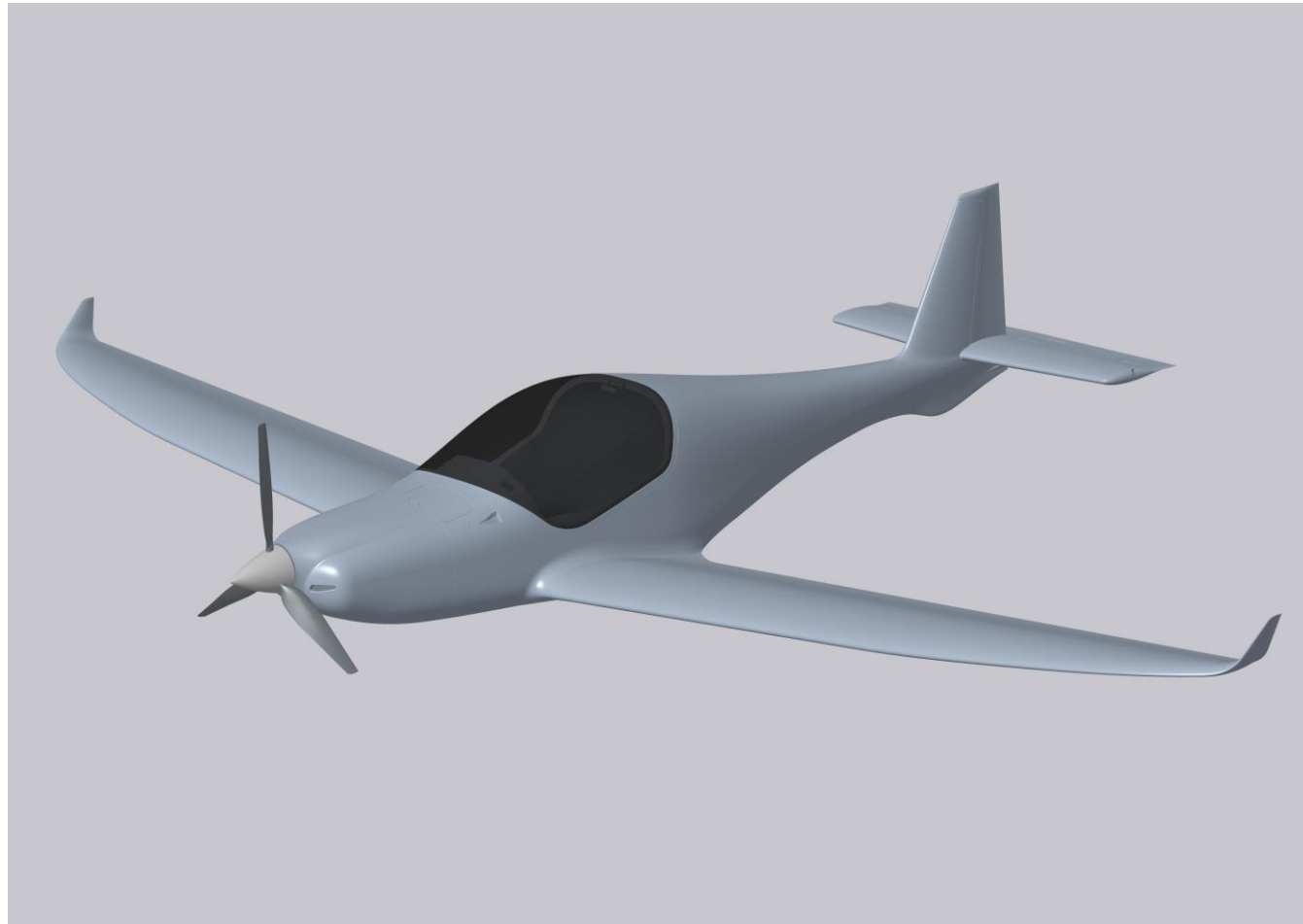

- Fixed gear trainer
- Short range travel
- Carbon fibre
- Modern aerodynamic with laminar flow – glider technology

The wing development

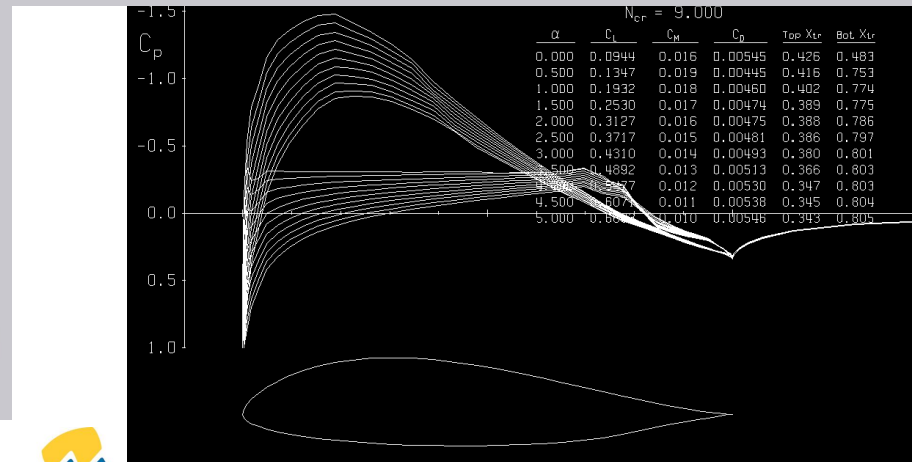
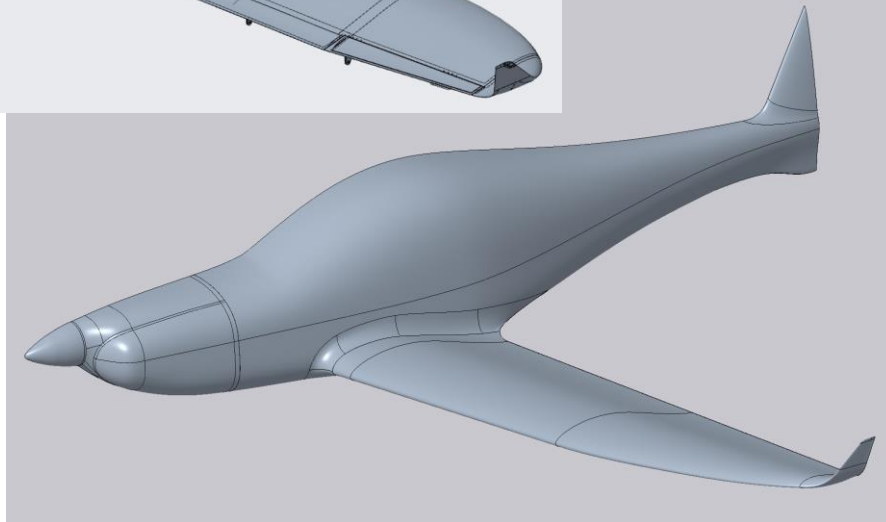
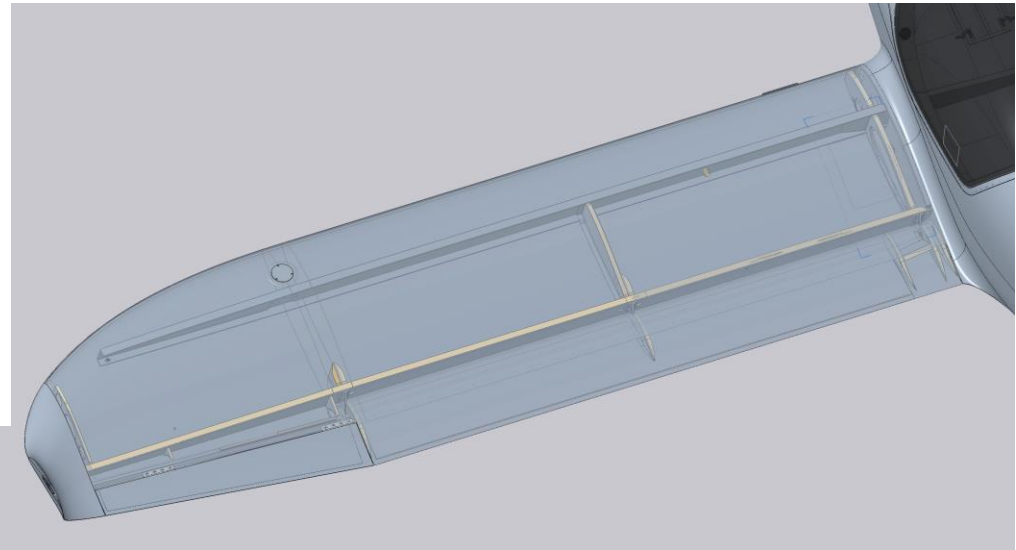
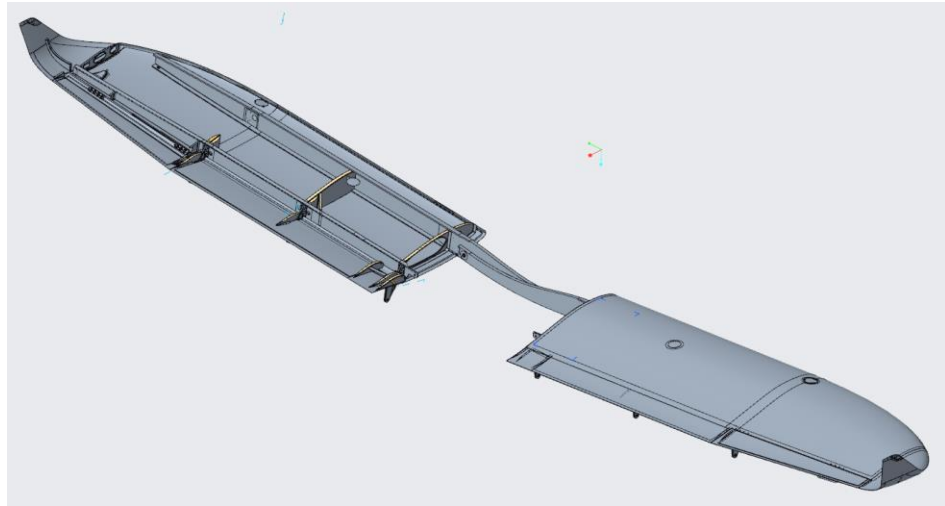

The wing development

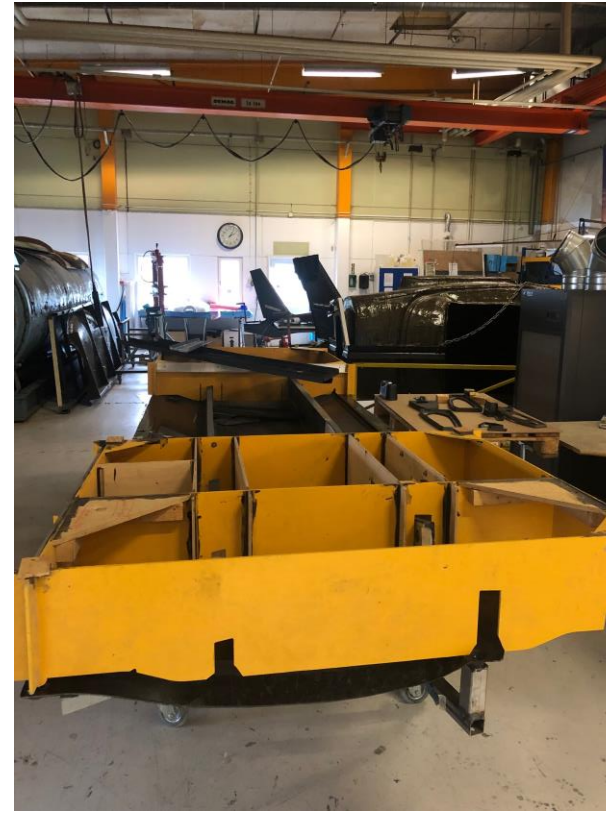
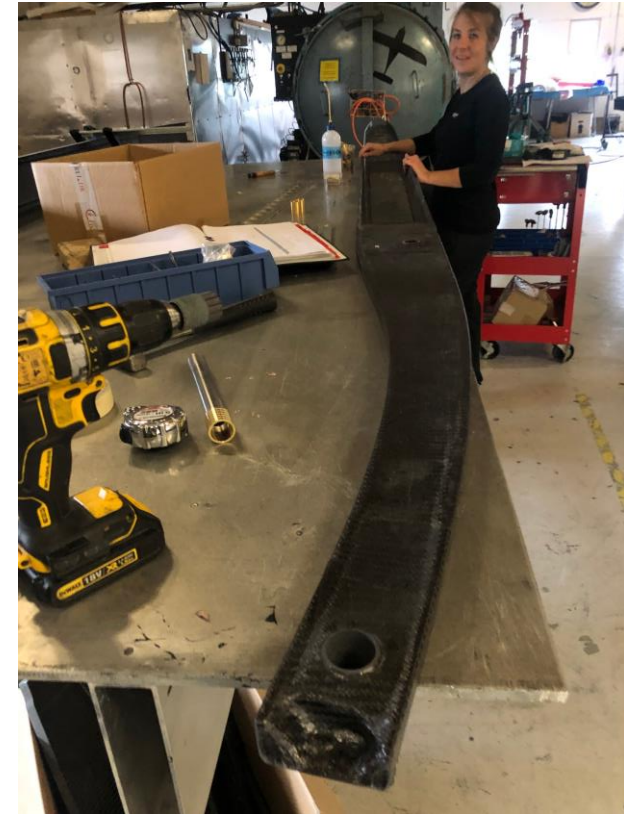

Roadmap

- GreenWing (20-25kW, 2h range).
- Design study for Electric Blackwing, February 2023
- Certification Swedish NLF, end 2023
- Certification EASA 2024



Vernamack AB



Questions?

???

